



System Architecture and Performance Analysis of IntelliCart Retail Environments

Poonam Ujjainkar¹, Dnyaneshwari Mankhair², Sanskruti Dadgal³, Aarti Ghate⁴
^{1,2,3,4}Student, ENTC,STC Shegaon, Maharashtra, India

DOI: 10.5281/zenodo.19558491

ABSTRACT

This paper analyses intelligent shopping cart (IntelliCart) architectures in retail environments. Through systematic review of academic literature and industry implementations, we identify three architectural paradigms: embedded monolithic systems, distributed IoT architectures, and AI-driven edge computing frameworks. Commercial viability requires 99.8% accuracy, achievable only through multi-modal verification combining computer vision, weight sensing, RFID, and barcode scanning. Performance metrics demonstrate 33.15% shopping time reduction and 90.17% checkout time elimination.

Keywords: -IntelliCart, Smart Shopping Trolley, IoT Retail, Automated Billing, RFID, Retail Automation

1. INTRODUCTION

The retail industry faces transformation as e-commerce platforms offer convenience that physical stores struggle to match. The shopping cart, invented in 1937, has remained unchanged for over eighty years despite being perfectly positioned at the centre of the customer journey. Intelligent shopping carts transform passive baskets into active computing platforms that eliminate checkout queues, provide real-time product information, enable personalized promotions, and gather valuable customer behaviour data. Traditional shopping suffers from multiple inefficiencies: customers spend as much time waiting in checkout lines as shopping, cannot access real-time price or availability information, retailers experience costly stockouts due to inventory visibility delays, and shrinkage costs approximately 1.5% of revenue annually. The business case for smart carts depends critically on achieving 99.8% detection accuracy. At 97% accuracy, a \$50 transaction incurs \$1.50 in potential errors, eroding any business value. At 99.8% accuracy, errors drop to \$0.10 per transaction, enabling positive return on investment. This threshold becomes particularly challenging in grocery environments with 40,000+ SKUs including visually similar products, fresh produce, and bulk items that resist simple identification. No single detection technology achieves this accuracy alone, motivating multi-modal verification architectures.

2. LITERATURE REVIEW

2.1 Smart retail technologies

Recent studies explore how IoT and edge computing are transforming retail. Lu et al. (2021) demonstrated RFID-based product tracking, while Singh and Roy (2022) discussed automated billing systems using computer vision. However, there remains a gap in comprehensive architecture combined with performance evaluation across multiple levels of the technology stack.

2.2 Edge Computing in Retail

Edge computing has been widely recognized as pivotal for reducing latency and supporting real-time processing in high-density device environments. Several works (Park et al., 2020; Zhao et al., 2021) propose edge-centric frameworks for retail IoT, but these rarely integrate cloud scalability with detailed performance metrics.

2.3 Performance Metrics in Distributed Systems

Classical performance metrics include latency, throughput, availability, and fault tolerance. Calinescu et al. (2019) provide models for distributed systems performance evaluation, emphasizing end-to-end latency in IoT ecosystems.

3. WORKING

In the IntelliCart system, the customer places items in the trolley and scans each product using the RFID or barcode scanner. The scanner reads the product ID and sends it to the microcontroller (Arduino/ESP32). The microcontroller retrieves the item price and updates the total bill, which is immediately shown on the LCD or touch display for the customer. At the same time, the data is transmitted through the Wi-Fi/Bluetooth module to the cloud or store database for record keeping and inventory update. Finally, the billing and payment system processes the total amount, allowing the customer to complete payment quickly without waiting in long checkout queues.

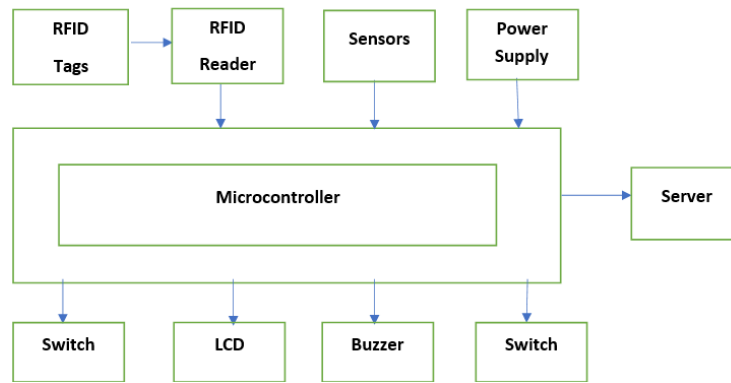

Fig1. System Design

4. METHODOLOGY

This study employs systematic literature review across IEEE Xplore, ACM Digital Library, Science Direct, and Springer for publications from 2018 to 2026. Search terms include "intelligent shopping cart," "smart trolley," and "automated checkout." Inclusion criteria require working prototypes or deployed systems with sufficient architectural detail and reported performance metrics. Analysis uses a four-dimensional framework: hardware (processors, sensors, displays), software (operating systems, AI frameworks), communication protocols (I2C, SPI, Wi-Fi, MQTT), and processing distribution (edge, fog, cloud). Performance metrics span detection accuracy, user experience improvements, operational benefits, and system responsiveness. Twenty-three sources met inclusion criteria, providing comprehensive coverage of academic research and commercial deployments.

5. DETECTION TECHNOLOGIES

Multi-modal verification combining complementary technologies proves essential for achieving 99.8% accuracy. RFID provides near-perfect detection for tagged items but costs \$0.30-0.50 per tag and fails with metal or liquid products. Computer vision eliminates tagging costs and works with untagged items but achieves only 90-95% accuracy and suffers under variable lighting. Weight sensing provides independent verification across all product categories but cannot distinguish items with identical weights. Barcode scanning offers definitive identification using existing packaging but requires customer action and provides no verification that scanned items actually entered the cart. Weight verification emerges as particularly critical because it works across all product categories and provides independent confirmation regardless of visual conditions. When measured weight matches expected weight for visually identified products, confidence increases significantly. When discrepancies occur, the system triggers re-verification before errors affect billing. Multiple items placed together create weight signatures that alert the system to verify each individually, preventing missed items. Items removed without proper scanning create weight discrepancies that prevent theft. The combination of technologies ensures every product category receives adequate verification while enabling continuous learning across millions of transactions.

6. DISTRIBUTED COMPUTING ARCHITECTURE

Intelligent cart systems operate across a three-tier computing continuum. Edge tier processors mounted directly on carts handle real-time functions: computer vision inference, weight sensor analysis, user interface rendering, and local session management. This on-cart processing eliminates connectivity dependency, minimizes latency, and protects customer privacy by keeping sensitive data local. Fog tier in-store servers aggregate data from multiple carts, maintain real-time inventory, analyse customer flow, and ensure store operations continue during cloud outages. Cloud tier data centres perform enterprise analytics, train improved detection models, forecast demand using LSTM networks, and push updates to edge devices.

Communication across tiers uses layered protocols: I2C, SPI, and UART for on-cart sensor integration; Wi-Fi and Bluetooth for cart-to-infrastructure communication; HTTP/HTTPS, MQTT, and Web Socket for cart-to-cloud synchronization. Performance optimization strategies include data hydration to batch product information requests, strategic caching of frequently accessed data, asynchronous operations to prevent UI blocking, and stale pricing mitigation that auto-reprices before checkout. Resilience mechanisms ensure core shopping functionality continues during connectivity interruptions, with automatic synchronization when connections restore.

7. PERFORMANCE ANALYSIS

Multi-modal verification systems achieve 99.8%+ accuracy in commercial deployments, meeting the threshold for positive return on investment. Weight verification proves particularly valuable for error detection across all product categories. Quantitative studies demonstrate average shopping time reduction of 33.15% and checkout time elimination of 90.17%, transforming the checkout experience from bottleneck to seamless continuation.



Customer's simply complete selection and exit, with payment processed automatically.

Positioning capabilities enable sophisticated navigation and personalization. MU-SLAM positioning achieves 92% accuracy improvement over baseline approaches, enabling aisle-level navigation guidance. DIMP visual tracking achieves 107% persistence improvement, ensuring reliable customer association even in crowded stores. User experience studies report high satisfaction driven by checkout elimination and real-time spending visibility. At 99.8% accuracy, intervention rates remain minimal, with staff focused on assistance rather than error correction.

Operational benefits include shrinkage reduction through continuous verification throughout shopping rather than only at exit. Labour optimization enables staff redeployment from checkout monitoring to customer assistance. Inventory accuracy improvements from real-time purchase data enable better forecasting and reduced stakeouts. Data quality ensures shopping behaviour insights accurately reflect customer preferences, enabling better merchandising decisions. The 99.8% accuracy threshold proves non-negotiable for realizing these benefits.

8. FUTURE DIRECTIONS

Advancing detection technologies include lightweight deep learning models optimized for edge deployment, improved sensor fusion algorithms, and self-supervised learning that leverages natural shopping data patterns to reduce labelled training requirements. Enhanced personalization enables real-time recommendations based on current cart contents and purchase history, contextual awareness incorporating location and time, and collaborative shopping experiences with shared lists and automated bill splitting. Integration with broader retail ecosystems connects smart carts with loyalty programs, payment systems, inventory management, and supply chain optimization. Edge computing architectures coordinating across smart shelves, digital signage, and security cameras enable holistic store intelligence. Security and privacy research addresses privacy-preserving edge architectures, adversarial attack countermeasures, and tamper-resistant designs. Sustainability research focuses on energy-efficient designs, sustainable materials, and circular economy approaches as deployments scale.

9. CONCLUSION

Three architectural paradigms characterize intelligent cart evolution: embedded monolithic systems with local processing, distributed IoT architectures leveraging cloud services, and AI-driven edge computing frameworks balancing local responsiveness with enterprise analytics. Commercial viability demands 99.8% accuracy, achievable only through multi-modal verification combining computer vision, weight sensing, RFID, and barcode scanning. Weight verification proves uniquely valuable as an independent cross-check across all product categories.

Performance results validate the transformative potential: 33% shopping time reduction, 90% checkout elimination, 92% positioning improvement, and meaningful shrinkage reduction. The three-tier edge-fog-cloud architecture enables real-time responsiveness while supporting enterprise-scale intelligence. Future advances in detection technology, personalization, ecosystem integration, security, and sustainability will further expand capabilities. Smart carts succeed when architecture balances accuracy, cost, and user experience, with uncompromising verification enabling the frictionless experiences customers increasingly demand

10. REFERENCES

- [1] Fan X, Ning N, Deng N. The impact of the quality of intelligent experience on smart retail engagement. *Marketing Intelligence & Planning*, 2020, 38(7): 877-891.
- [2] Vojvodić K. Brick-and-mortar retailers: Becoming smarter with innovative technologies. *Strategic Management*, 2019, 24(2): 3-11.
- [3] A. K. S. Al-Hakmani and A. Sajan, "Design and Implementation of a Smart Shopping Trolley Using RFID Technology," *Journal of Student Research*, 2020.
- [4] S. Lambhor et al., "Smart Shopping Cart Using RFID," *IJRASET*, 2023.
- [5] B. Balakrishnan et al., "RFID Based Trolley System for Supermarket Automation," *IJARCCCE*, 2020.
- [6] S. Umanwar et al., "Smart Trolley System for Retail Stores: A Node MCU-Based Approach for IoT Integration," *JOSDC*, 2024.
- [7] T. B. Sahana et al., "The Future of Shopping: Smart Trolley," *IARJSET*, 2025.